



## CONTACT US



-  12005 N. Burgard Road, Portland, OR 97203
-  (503) 286-7791  
(Rapid Response available 24/7)
-  [info@westernmachine.com](mailto:info@westernmachine.com)
-  <https://westernmachine.com>

# WIND TURBINE REPAIR SERVICES



# OUR SERVICES

Western Machine Works is well equipped to repair the world's leading wind turbine brands and models for OEMs, O&M providers, ISPs, and wind farm owners.



Western Machine Works has the skilled technicians, project management, custom tooling, and engineering expertise to handle all aspects of main shaft refurbishing.

Custom tooling and fixtures are designed to efficiently and correctly assemble main shaft components. Critical dimensions of all main shaft components are documented during the disassembly and inspection process.

## SPECIALIZED SOLUTIONS FOR THE WIND POWER INDUSTRY:

### MAIN SHAFT RESTORATION

- ✔ Certified main shaft repair facility since 2007.
- ✔ Main shaft disassembly and assembly.
- ✔ Dimensional inspection of all components.
- ✔ Bearing inspection and failure analysis.
- ✔ Non-Destructive Testing.
- ✔ Bearing fit repair using thermal spray processes, which restores the bearing fit to OEM sizes, improves surface characteristics, and adds resistance to fretting corrosion.
- ✔ Bearing fit repairs and re-machining to accommodate custom undersized bearings.
- ✔ Sourcing for unique bearings and sealing components.
- ✔ Sealing assembly repairs and upgrades.



 CERTIFIED MAIN SHAFT REPAIR FACILITY SINCE 2007

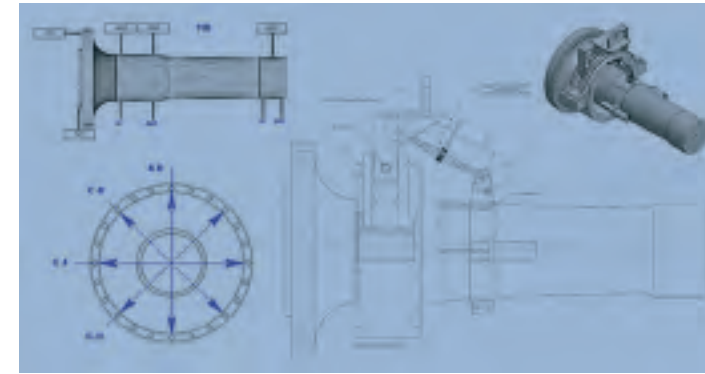

### ENGINEERING

To improve reliability and ensure efficient operation of your main shaft assembly, our engineering team evaluates dimensional data and failure analysis results to determine design upgrades. We also have the in-house capability to reverse engineer and manufacture new components.



### BEARING EVALUATION AND ANALYSIS

- ✔ Main Bearing Cleaning, Inspection and Failure Analysis.
- ✔ Yaw Bearing Cleaning and Inspection.
- ✔ Blade Bearing Cleaning and Inspection.
- ✔ Bearing Housing Restoration.

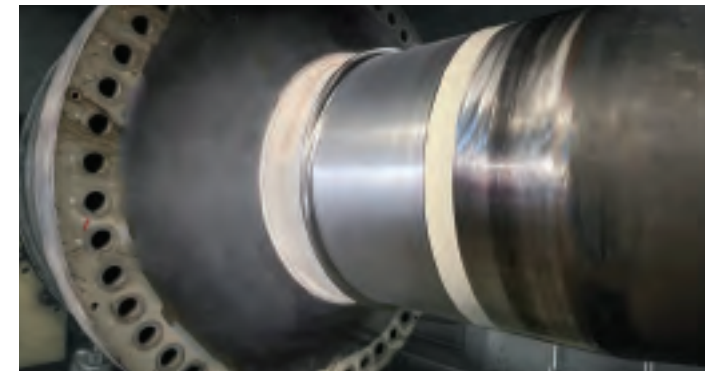

### THERMAL SPRAY COATING

- ✔ Restore the wind turbine's main bearing fits and worn-out surfaces to factory specifications or better using twin wire arc thermal spray coating process.
- ✔ Smart arc applied 420 stainless steel coating with bond strength approaching 10,000 psi.
- ✔ Compliant with formal OEM coating approval process, which includes laboratory analysis of coating purity, integrity, bond strength and fretting corrosion resistance.
- ✔ Provides a superior bearing fit surface that is resilient to fretting corrosion.
- ✔ Over 300 wind turbine main shaft bearing surfaces repaired without failure.



### PROJECT MANAGEMENT AND TRANSPORTATION

- ✔ Expert technical and logistics project management services allow you to get back to work.
- ✔ Custom lifting and transportation fixtures ensure your equipment is protected.
- ✔ Company-owned truck fleet ensures prompt, prioritized service.
- ✔ Minimize downtime with our 24/7 service.



## WHO WE ARE

Western Machine Works was established in Portland Oregon in 1985 as a full-service machine shop specializing in all facets of equipment repair, upgrades, and new manufacture. More than just a machine shop, WMW provides engineering-focused approach to its repairs, refurbishments, and fabrications. Its 34,000 sq. ft facility is equipped to handle machining, grinding, balancing, welding, and metallizing of large rotating equipment and shafts for the Wind, Hydroelectric, Marine, Pulp & Paper, and other heavy industries. WMW provides reliability while offering reverse engineering, on-site measurements of critical components, in-house transportation services, 24/7 rapid response, and total project management. Minimize downtime and achieve wind power generation efficiency with Western Machine Works.

